

Chapter 1 Rationale and General Information

1.1 Introduction^[1-5, 11, 13,14]

The respiratory gating system was pioneered in Japan for use in proton and heavy ion radiation therapy procedure. In 1991, the Tsukubo Proton Medical Facility commissioned the first breathing gated radiotherapy system, which make use of a 2 cm diameter strain gauge taped to the patient's flank near the umbilicus for supine treatment and the corresponding site at the dorsal region in the prone position. This system was a major part of the 500 MeV proton treatment center, and has play a major role in treatment process of tumors, because gating for motion uncertainties is an important ancillary for accurate proton radiation treatment. In 1996, the National Institute of Radiological Sciences (NIRS) in Chiba, employed a breathing monitoring system (BMOS) using a light emitting diode (LED) as fiducial marker, which is taped to a certain part of the body. The system includes a position sensitive detector (PSD) rigidly mounted on the couch used to track the movement of the LED fiducial markers during the duration of the heavy ion carbon-12

radiation therapy. Both these systems are prototype gadgets.

Treatment setup for most thoracic and abdominal tumors are affected most seriously by the constant movement brought about by the diaphragmatic movement during respiration cycle, which were corrected previously by increasing the margin of the planning target volumes (PTV), resulting in an increase in the amount of normal tissues encompassed within the PTV area during radiation treatment (Figure 1 and 2).

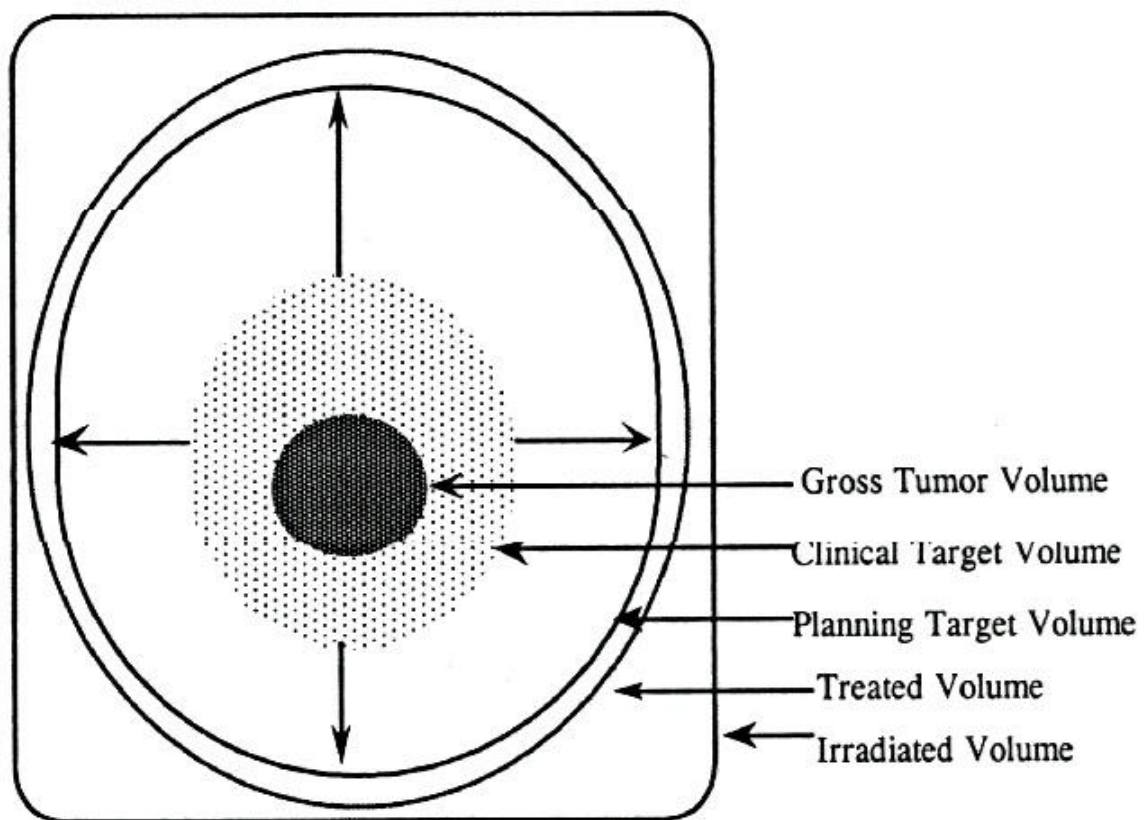

Figure 1 ICRU 50 Definition of the commonly used term in treatment planning of malignant tumor.

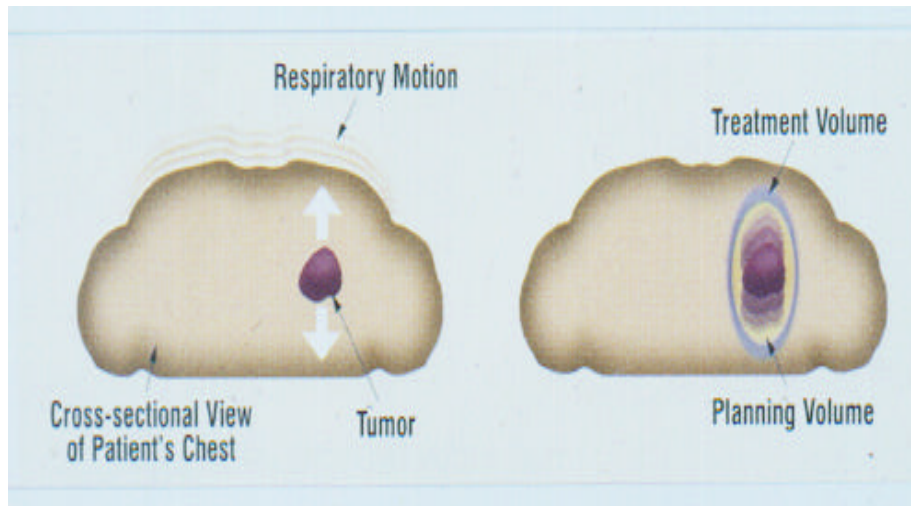

Figure 2. Organ motion and added margins around a clinical tumor volume (CTV) to form a planning target volume (PTV)

To localize the dose to a moving target, other methods have been proposed aside from increasing the margin around the PTV. Two other types of method have been proposed. One method is to control the target movement by keeping the breath of the patient artificially paused during irradiation by application of a breathing control gadget. The other method is to irradiate the beam on a moving target synchronized with the patient respiratory movement. In other words, gating the respiratory motion. The value of the respiratory gating system lies in its ability to decrease the amount of normal tissues encompassed within the PTV, which can translate into dose escalation in the

target volume, resulting in greater tumor control probability (TCP) and decreasing the injury to the normal tissue, leading to decrease normal tissue complication probability (NTCP).

1.2 Aim of Study and Rationale ^[2-9, 11, 13-20]

Uncertainties due to complex organ related motion has been a major factor to consider in carrying out radiation treatment procedures. This movement may be classified into three categories: namely (a) patient position-related organ motion, (b) interfraction organ motion, and lastly, (c) intrafraction organ motion. The prior to problems can be resolve by strict guideline in patient setup and good immobilization and repositioning system and devices. The last problem would be the problem tackle by this study. With the advent of highly sophisticated computer-controlled high energy linear accelerator treatment machine, control of the uncertainties inherent in patient setup and machine accuracy has tremendously improved and accurate localized radiation treatment has become an every day routine. Unfortunately one variable that is very hard to control is that of

internal organ motion brought about by the respiratory movement of the patient. Several studies have shown that this inconsistency could have very grave consequences on both tumor control probability (TCP) and normal tissue complication probability (NTCP). Inconsistencies within the treatment portal could be as high as 3 cm in ungated condition, which means that much normal tissue would be irradiated. Incorporation of the respiratory gating system is not only limited to the field of radiation therapy but can also be a very useful tool in performance of CT scan, MRI imaging and PET scanning. It can help reduce or if not totally remove the motion factor that may introduce motion artifact into the images, thus we can be more confident in assessing the exact region of the body where the tumor is located and the true dimension of the tumor, by incorporating the system to the CT scanning session or even for MRI studies, it will revolutionize the way we treat malignancies. In this study, we would try to assess the accuracy and dependability of our new Real-Time Position Management Respiratory Gating System (RPM)(Figure 3, Figure 4). The

technical aspect of its functionality in term of the dependability and accuracy of the tracking system and the consistencies of respiratory movement would be assess and compare between individuals, in order to correlate the clinical usefulness of the RPM system in conjunction with planning and accurate delivery of the external radiation treatment of malignant tumors. The purpose is to investigate the potential displacement of tumor during organ motion due to respiration, and how a respiratory gating system could be applied to reduce treatment margin and spare normal tissue. The eventual aim of this paper is to assess if the new system is an accurate and dependable gadget and if it could be integrated into our daily radiation therapy routine. We also hope to identify the type of tumor best suited to use this new system in the routine radiation therapy setting. We would also search the literature for other methods for controlling these types of uncertainties, and try to expound on the future development in this field of the radiation therapy ancillary system. We hope with this thesis, we can be more confident with the systems functions.

VARIAN
medical systems

The integrated solution

Delivery Systems - Respiratory Gating

- ▶ System for Simulation and Treatment
- ▶ CCD Camera with retro-reflecting markers
- ▶ Windows NT- Computer
- ▶ Software for beam control

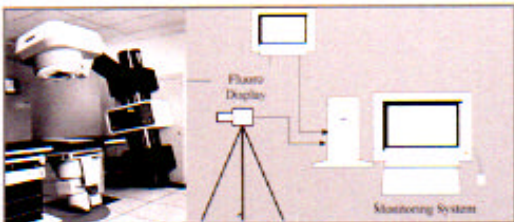





Figure 3. Varian RPM Respiratory Gating System



Figure 4. Varian RPM Respiratory Gating System

Chapter 2 Historical Development and Literature Reviews

2.1 Development of Gating System^[1-5, 11, 13,14, 19-29]

Fractionation is a widely practiced scheduling scheme in radiation therapy delivery which is based on the radiobiological premise that dividing the total radiation dose into smaller fractions would minimize the damage inflicted on the normal tissue surrounding the planning target volume (PTV), while maintaining a near maximal tumor cell kill in the PTV region. Clinically the normal tissues would have time to better recuperate from the injuries of previous radiation treatment, while such mechanism is not efficient in tumor cells, thus in fractionation, such differential effect could be taken advantage of. The inherent disadvantage in this scheduling scheme is the problem of accurate repositioning of patient on a daily basis, with natural organ motion compounding the problem. The former disadvantage has been resolved by the state of the art computerized treatment delivery system and repositioning

system, which has been extensively studied previously and has many published papers concerning its implementation.

Development of accurate computer-controlled treatment machine with inaccuracies measured in millimeter, coupled with highly reproducible repositioning system has resolved the problem of daily treatment position reproducibility. Highly advance and accurate treatment delivery system and dependable immobilization system coupled with computer guided targeting system are widely available on the commercial market. The plethora of data on such system and gadget would be too extensive to cover in this paper. But the latter problem of organ motion has been a compounding problem, which is just being address recently and the methods and technique are still in infant development.

The respiratory gating system was pioneered in Japan for use in proton and heavy ion radiation therapy procedure. In 1991, the Tsukubo Proton Medical Facility commissioned the first breathing gated radiotherapy system, which use of a 2 cm diameter strain gauge taped to the patient's flank near the

umbilicus for supine treatment and the corresponding site at the dorsal region in the prone position. This system was a major part of the 500 MeV proton treatment facility, because gating for motion uncertainties is an important requirement for accurate proton radiation delivery. In 1996, the National Institute of Radiological Sciences in Chiba, employed a breathing monitoring system (BMOS) using a light emitting diode (LED) as fiducial marker, which is taped to a certain part of the body. The system includes a position sensitive detector (PSD) rigidly mounted on the couch used to track the movement of the LED fiducial markers during heavy ion carbon-12 radiation therapy. Both this system are prototype machines. They were beset by a lot of deficiencies, they were cumbersome to handle and need quite a while to setup and has the limitation in treatment position, being limited to the antero-posterior and lateral portal treatment. Newer systems are being developed to deal with the impracticability of the prototype machine.

2.2 System Overview^[5]

Through gating, the margin around the target volumes could

be minimized, which might otherwise be quite large to accommodate for tumor motion during respiration. The Real-Time Position Management Respiratory Gating System (RPM) tracks the patients' respiratory motion using a video camera connected to a PC workstation. The video camera tracks the passive markers (luminescence fiducial) attached to a marker block, which is in turn attached to the patient's chest or abdominal region (Figure 5). The system keeps and displays records of the respiratory motion in a moving strip chart that you view on the monitor screen (Figure 6). One system is placed in the simulation room where it is used to acquire the initial respiratory motion data and a synchronized fluoroscopic picture of the diaphragmatic movement. The data are used for planning the duty cycle needed for treatment, which in turn controls the signal sent to the linear accelerator. The system sends a stop signal to the linear accelerator to stop the radiation beam (trigger beam-hold) when the target volume moves out of the limits or threshold programmed in the computer, to reduce delivery of radiation to adjacent healthy tissue.

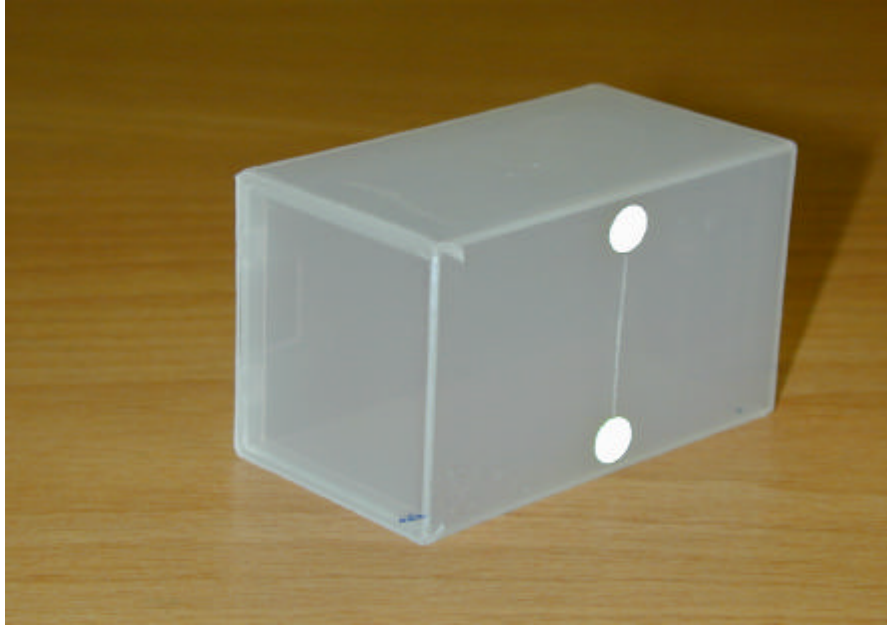

Figure 5. The block marker place on the patient chest or abdominal region.

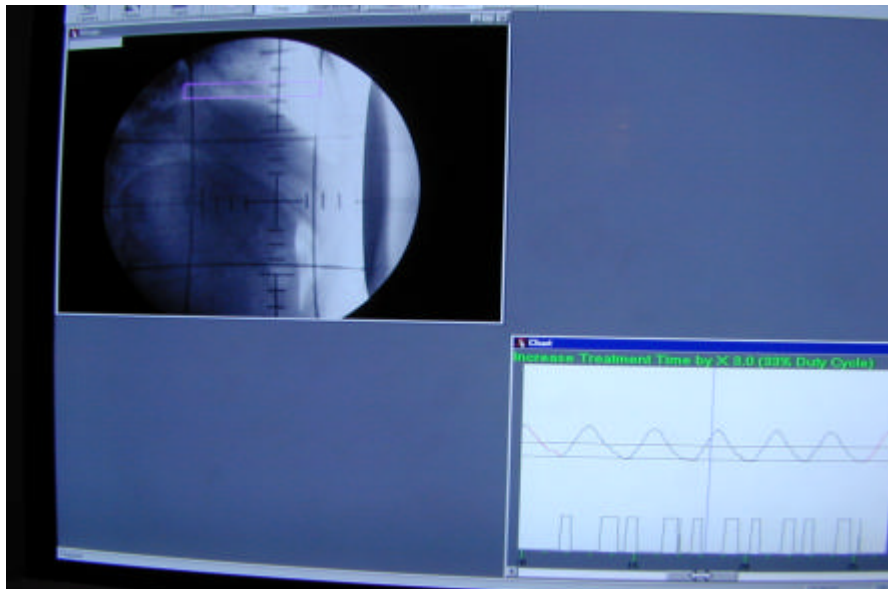

Figure 6 The monitor screen displaying the chart of the motion data and the fluoroscopic image of the patient organ motion.

In a simulation session, we acquire planning data from the simulator, with either a fluoroscopic or computed tomography (CT) scanner.

- In fluoroscopy, we record a live video image from the fluoroscope, which is synchronized with the graphical rendition of the respiratory motion data (Figure 6).
- In a CT scanner, the system uses the respiratory motion data to trigger the scan acquisition in synchronization with the respiratory motion data.
- In planning session, we first determine the target volume to be treated, then we determine when the target volume is within a range of positions called the gating interval, adjusting the gating thresholds in the recorded data.
- In fluoroscopic simulation, we play back the recorded data and use the fluoroscopic image to adjust the gating interval. Gated playback allow us to observe the image record for the period within the interval, so we can see where the target volume will be with respect to the radiation beam.
- In CT scan, we set the gating interval based on the

synchronized scan and motion data.

We can choose to set gating thresholds either by phase or by amplitude, and save the parameters for the gating interval as part of the motion data. The actual treatment is delivered in the treatment room, where we play back planning session in the treatment room, where the software uses the gating parameters to determine when to hold the radiation beam. During gated treatment, the beam is on only within the gating interval.

The digital image analysis and video tracking software runs on a Windows NT[®] workstation. We store the treatment planning data on the PC workstation.

The main part of the RPM Respiratory Gating System main menu window has a menu bar, a toolbar, a main display area and a status bar (Figure 6). Before taking any action, we select a database and specific patient and session record. The title of the main window then shows the current patient and treatment session.

When we have selected a patient and session, two

smaller windows appear in the main display area:

- The image window display video images from either the camera or the fluoroscope.
- The chart window plots the motion data in the form of a moving strip chart, and shows the relative phase of the respiratory cycle in a dial image.

The sequence of tasks for doing the respiratory gating is illustrated in the schema diagramed below, with the clinical processes of simulation, planning and treatment.

The hardware components and schema of the simulator setup and the treatment room setup are illustrated in the following figures (Figure 7, 8, 9, 10, 11)

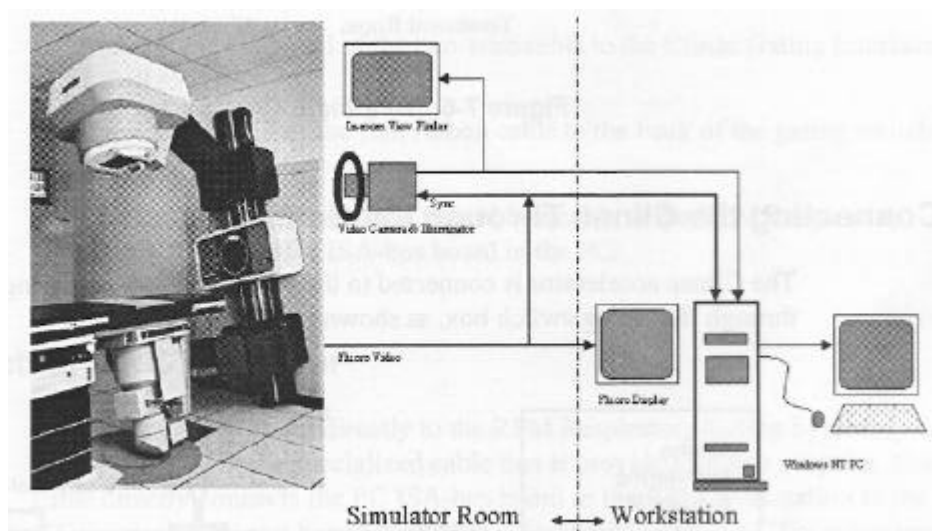

Figure 7 Schema of the simulator system components

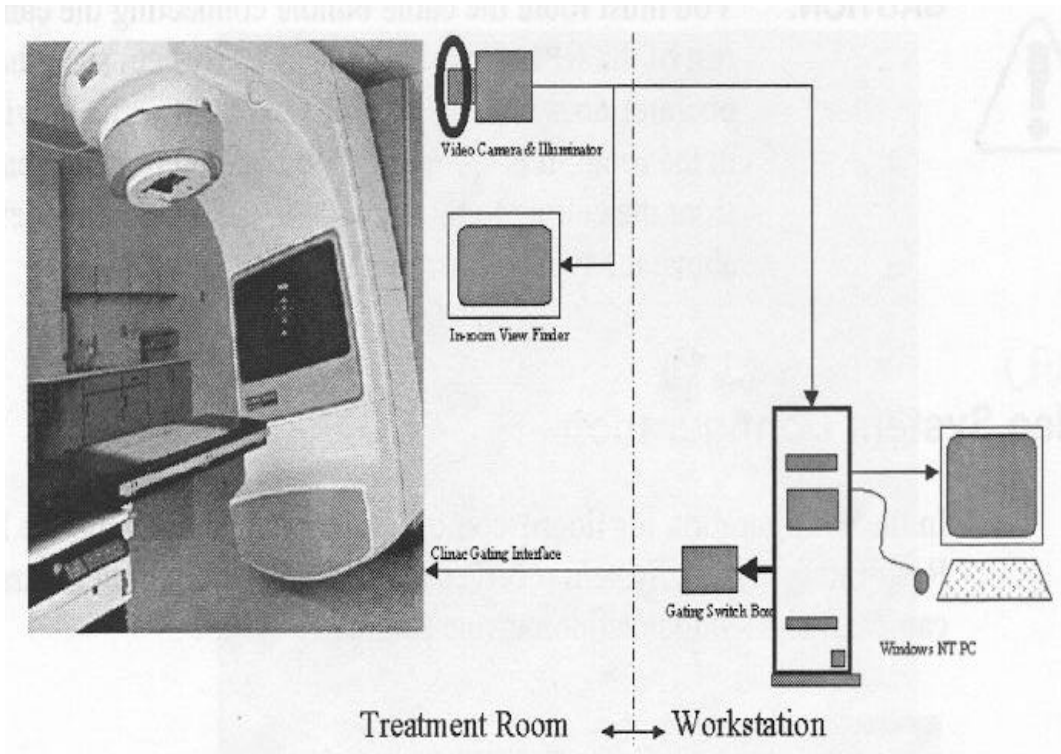

Figure 8 Schema of the treatment room system components

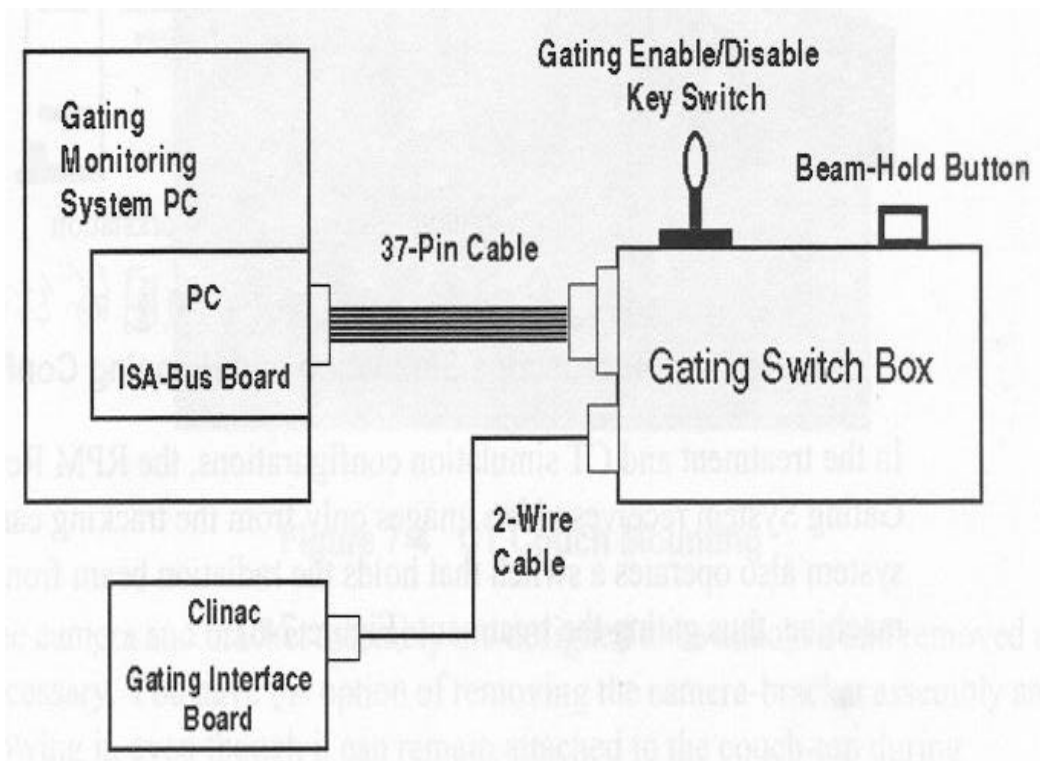

Figure 9 Schema of the control system components

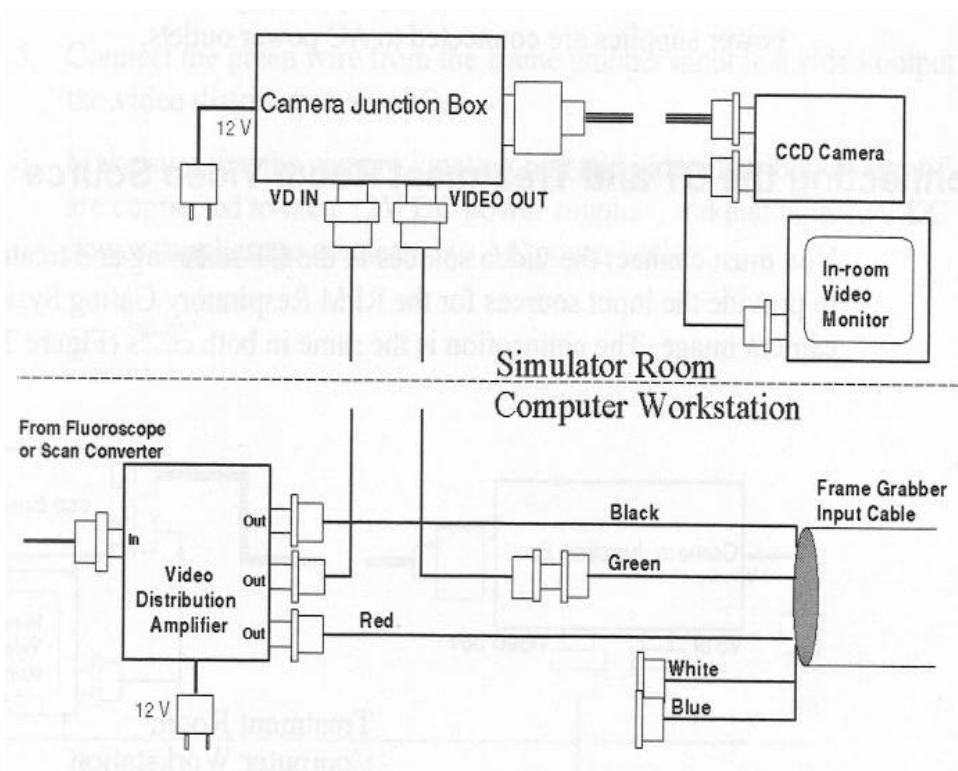

Figure 10 The schema of the circuitry of the control for the fluoroscopic system.

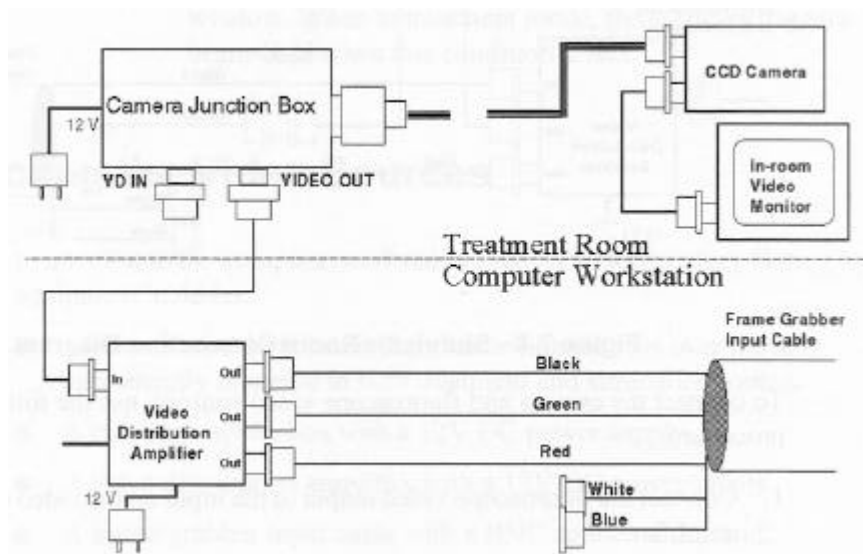

Figure 11 Schema of the circuit of treatment room controls.

2.3 Usage of Respiratory Gating System

The use of gating system is not limited to the field of radiation therapy, but has been developed for use also in the field of imaging, including magnetic resonance imaging (MRI), Computer-assisted Tomography scanning (CT-scan), and other procedure which are affected by organ motion artifact. The method of gating is generally divided into static gating and dynamic gating. Most of the present day techniques are base on static control of organ motion by controlling the treatment delivery based on the location of the fiducial on the patient's body surface. This type of controls has one disadvantage, which is increase of the treatment time due to the fact that the treatment is stop in half of the treatment time. Newer concept are being develop which would make use of the whole of the treatment time by either synchronizing the couch movement to the respiratory movement to moving the MLC in conjunction with the rhythm of respiration.

Chapter 3 Material and Methods:

In Chung Shan Medical University affiliated Medical Center, Department of Radiation Oncology, we acquired a prototype respiratory gating system from the Varian Medical System to incorporate into the daily treatment of tumor of region in the para-supradiaphragmatic and para-infradiaphragmatic region. The system is a beta version of the respiratory gating system under development. We initially tested the accuracy and dependability of the system by doing respiration motion studies in 11 normal volunteer subjects from our staff. We try to find out the clarity of the fiducial tracking of the infra-red camera of the system. At the same time we try to identify the regularity of individual breathing cycle to assess the feasibility of it use in clinical setting. The system works by using a plastic cubicle with reflective fiducial marker, which we called patient marker block, which is place on the subject's chest wall and the region is marked with marking pen. Then the subject is made to lie down on the treatment table. A Varian Ximatron simulator was use in the study. An infrared laser with a infrared detecting

camera was placed at an area above the study subject to do the tracking of the fiducial marker at the subject chest wall. The camera acquired the image, which is then translated into digital signal and can be interpreted by the system software and thus the chest movement is translated into sine wave plotted against a time frame. The data are stored up in the databank of the system and file under a special file name. We initiated use of the system in 30 consecutive patients with their prior consent, to decrease the PTV volume. Dataset includes comparison of the software generated measurement with that acquired by manual measuring the fluoroscopic image of the organ motion, thus letting us know correlative relationship of this two data.

3.1 System Components

The RPM Respiratory Gating System was designed to operate with state of the art dual photon energy Varian Clinac 21EX linear accelerator system running on software version 6.1, with dynamic MLC capability. The major components of the system includes the following:

3.1.1 A patient marker block, which is attach to the patient exterior and use to track the external respiratory movement. (Figure 12)



Figure 12 Marker place on the patient's chest and being track by the CCD camera.

3.1.2 A charge-coupled device (CCD) tracking camera use to capture video images of the patient and the marker. (Figure.13)



Figure 13 Infra-red laser system with CCD tracking camera.

3.1.3 An in-room monitor or view finder that shows the real-time image of the marker as tracked by the tracking camera. It is use to adjust the position of the marker on the patient body surface.(Fig. 14)



Figure14 An in-room monitor to visualize the tracking situation.

3.1.4 A PC workstation running the system software. The monitor displays the motion data, live video images from the tracking camera and fluoroscopic images of the internal organ movement is displayed on the monitor with eventual synchronization done in the PC workstation. (Fig.15)



Figure 15. Picture of the Varian PC workstation.

3.1.5 A Gating switch Box (in the treatment room) which can be use to manually switch-off the beam or manually disable the RPM Respiratory Gating System during treatment.(Fig 16)



Figure 16 The gating switch box

3.2 Materials and Data Collection

We initially enrolled 11 volunteers from our staffs to verify and visualized the congruity of the image acquisition with the actual chest wall movement by the CCD system and that presented by the software. Then we enrolled 30 consecutive patients who were candidate for radiation therapy for the paradiaphragmatic region to be use as subject of the study. The patients has written their inform consent to be enter into this study. The data were collected by the workstation and saved as

individual files, and were later retrieved for measurement and analysis of the data.

3.3 Analytical Methodology

We collected the raw data, and we use SPSS software to do paired T-test to evaluate the significance of the differences in the values given by the software and that measured by our staffs.

We treated data as group according to the area where the measurement were done.

Chapter 4 Results and Discussions

4.1 Results of Study

From the data on the 11 volunteers, we track the chest wall movement by placing the marker block on the chest wall of the volunteers, using the infra-red laser with CCD camera, we track the chest wall motion and try to correlate the actual motion of the chest wall with that of the track by the camera and we found that there was good visual correlation of the chest wall motion and the sine wave of the chart. After being reassured of the accuracy of the tracking system, we subsequently use the system to track the respiratory motion of the 30 consecutive patients, chest wall movement track as sine wave versus time in a chart is coupled with the fluoroscopic images of the actual motion of the internal organ. The amplitude of the sine wave motion of the chest wall movement is measured, and compared with the amplitude of the actual chest wall displacement as measured from the fluoroscopic image to try to correlate the congruity of the two sets of data. We acquired the measurements in the upper area, which included the chest wall region and in the lower area,

which included the upper abdominal region. The results were listed in table 1.

Table 1. A Respiratory Gating System of the Organ Motion (n=30)

Organ	Average Displacement		Average Breathing Cycle(τ)
	(mm)(\pm SD)		(\pm SD)
	Free Breathing	50% Duty Cycle	
Upper Area AP	8.73 \pm 4.57	3.99 \pm 2.36	3.24 \pm 0.78
Upper Area SI	8.67 \pm 4.17	4.47 \pm 2.28	
Lower Area AP	10.72 \pm 5.24	5.01 \pm 3.14	3.32 \pm 0.93
Lower Area SI	13.83 \pm 5.65	7.27 \pm 3.53	

The results were compared using the paired t-test for significance, to see if the differences in the measured displacement in the anterior-posterior direction and the superior-inferior direction are significant. The results of the measurements revealed that there is good correlation between the movement in the anterior-posterior direction, as compare to the superior-inferior direction in the upper area, with the data revealing the anterior-posterior movement of the chest wall has an average value of 8.73 mm., s.d. 4.57, while in the anterior-posterior direction it was 8.67 mm., s.d. 4.17, paired t-test showed value of 0.086 with p value of 0.932, which shows

their difference is insignificant; While for the abdominal side, the anterior- posterior movement and the superior-inferior movement has not been shown to have good correlation, with the anterior-posterior movement having an average value of 10.72 mm, s.d. 5.24, while in the superior-inferior direction it was 13.83 mm., s.d. 5.65, paired t-test has a value of -3.289 , p value of <0.005 showing that their difference is significant and not by chance. We also did measurement at the 50% duty cycle, with the upper area showing the same relationship, the average displacement in the anterior-posterior direction measured 3.99 mm. s.d. 2.36 while in the superior-inferior direction it was 4.57 mm s.d. 2.28, paired t-test value was -1.481 , p value of 0.149 which is not significant, thus there is good correlation, while for the lower area, the average displacement in the anterior-posterior direction is 5.01 mm, s.d. 3.14, while in the superior-inferior direction it was 7.27 mm., s.d. 3.53, paired t-test value of -5.82 , p value of <0.005 which shows that the difference is significant, thus poor correlation. We also compare the differences in the breathing cycle measurement in the upper

area and the lower area, with value for the upper area is 3.24 seconds, s.d. 0.78 and for the lower area it was 3.31 seconds, s.d. 0.93, paired t-test value was -0.31 , p value was 0.757, which shows that the breathing cycle in the upper and lower area were measured under the same condition, with no significant difference in its magnitude (Figure 17). The breathing cycle could be approximated by the formula: ⁽⁷⁾

$$z(t) = z_0 - b \cos 2n \left(\pi t / \tau - \phi \right)$$

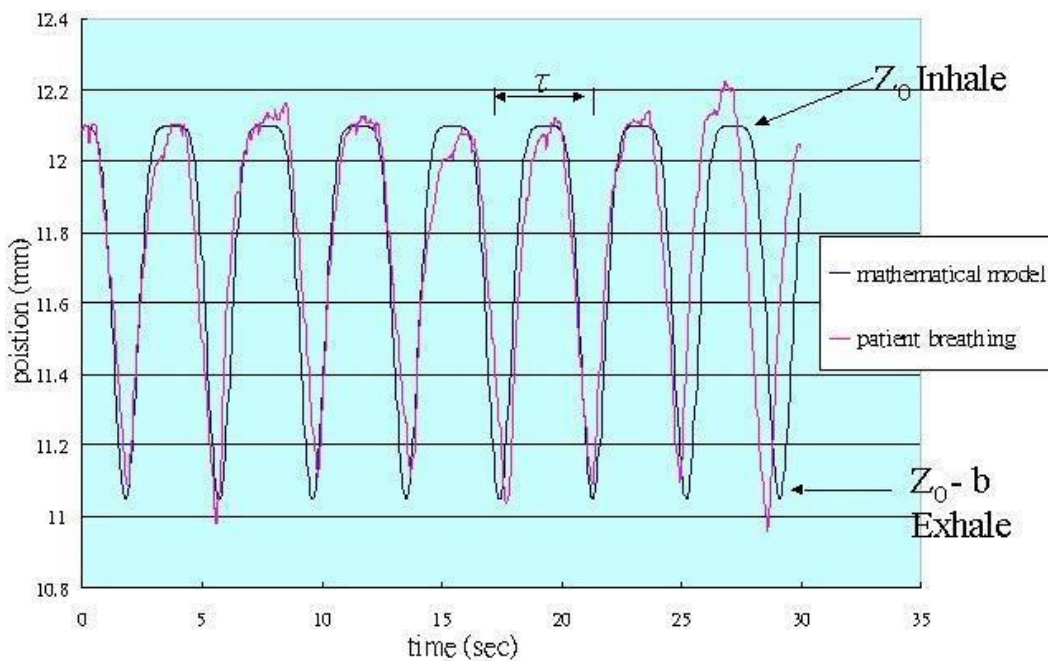

Figure 17 Position of breathing and mathematical model of data from $z(t) = z_0 - b \cos 2n \left(\pi t / \tau - \phi \right)$

In this formula, z_0 is the position at the exhalation, b is the extent (amplitude) of the motion, $z_0 - b$ is the position at

inhalation, T is the period of breathing cycle, n is a parameter that determines general shape (steepness and flatness) of the model, and ϕ is the starting phase of the breathing cycle.

We also cross analyzed the significance of the difference in changes between full respiration and 50% duty cycle respiration, in the upper anterior-posterior direction, and found the difference to be significance in both the upper and lower area, with the upper area, the paired t-test value of 10.192, p value of <0.05 , thus there is a real advantage in the used of respiratory gating in reducing the margin of the treatment field by a factor of 0.35, roughly reducing the size to $2/5$ of the original size, while in the upper superior-inferior direction, the paired t-test value was 10.74, p value was <0.005 , the margin factor was reduce by factor of 0.53, roughly $1/2$ of the original size. In the lower anterior-posterior direction, the difference were also significance, albeit to a smaller dimension, the t-test value was 11.212, p value of <0.005 , and the change of the size was factored by 0.46, roughly $1/2$ of the original size, while in the superior-inferior direction the difference were also significance,

t-test value of 12.03, p value of <0.005 , the margin factor was 0.52, roughly 1/2 of the original margin. Lastly, we did comparison of the motion in the anterior-posterior direction of the upper area and the lower region, which correlate quite well, with t-test value of -1.42 , p value of 0.17, thus we can say that the tracking ability of the RPM gating system is quite consistent in the anterior-posterior direction. Using 50% duty cycle yielded similar correlation with t-test value of -1.32 , p value of 0.196. The measurement in the superior-inferior direction is noted correlated well, with the full respiration cycle giving t-test value of -3.79 , p value <0.005 , and similar result for the 50% duty cycle, t-test value of -3.34 , p value <0.005 .

4.2 Discussion and Applications

We would caution in extrapolating the results from the chest wall region to that for the abdominal region, which was shown in our studies to be two heterogeneous groups. When acquiring data for the chest wall region, there is great correlation in the motion relationship in the anterior-posterior direction and the superior-inferior direction, which may be due to the fact that the

chest is encased in a rigid structure the rib cage, that motion in either the anterior-posterior direction is correlated well with the superior-inferior direction, but not in the abdomen, due to this very fact that it does not have a rigid casing. Overall the gating system is very good in that it was able to decrease the margin in the PTV by a factor equivalent to 50% of the original tumor volume.

Chapter 5 Conclusions and Future Developments

The dilemma we encountered in treating malignant tumors are quite varied. Accuracy of treatment delivery has been the foremost factor that has direct effect on curability of the malignant tumor and appearance of normal tissue complication. The accuracy of radiation treatment delivery has been beset with problem of various uncertainties which would tend to distort the precision of our treatment delivery. Amongst the problem to be tackle, the problem of natural organ motion has presented to be the most challenging problem in treatment delivery. The amount of available data varied among the different type of organs and type of motion involved. Knowledge of the nature and magnitude of organ motion is necessary to determine what type of control could be use to compensate or alleviate for the inconsistency that might arise. The amount of safe margin needed around the PTV largely depend on the ability to control the motion factor. Respiratory gating is a method widely employed today to control the motion uncertainty brought about by natural organ motion due to respiration. We have studied this

aspect of uncertainty and determine that gating method of organ motion control is very useful in reducing the effect of organ motion on the accuracy of treatment delivery, more precisely stated is, it could decrease the amount of safety margin around the PTV by as much a 50% of the original margin without the respiratory gating. When using the RPM respiratory gating system, it is important to be cautious in extrapolating data obtain in the chest region as compare to data from the abdomen, especially in the superior-inferior direction. We are expecting in the future that a more reliable and time-saving gating system maybe develop to maximize the use of the entire treatment duration thus would halve the present time needed for accomplishing the radiation treatment.

References:

1. Ohara K, Okunura T, Akisada A et.al: Irradiation synchronized with respiration gate. *Int J Radiat Oncol Biol Phys* 17;853-857, 1989.
2. Kubo HD, Len PM, Minohara SI, Mostafavi H: Breathing-synchronized radiotherapy program at the University of California Davis Cancer Center. *Med Phys* 27(2); 346-353, 2000.
3. Minohara SI, Kanai T, Endo M et. al.: Respiratory gated irradiation system for heavy ion radiotherapy. *Int J Radiat Oncol Biol Phys* 47; 1097-1103, 2000.
4. Kubo HD, Hill BC: Respiration gated radiotherapy treatment: a technical study. *Phys Med Biol* 41;83-91, 1996.
5. The Real-Time Position Management Respiratory Gating System User Guide. Varian Medical Systems, Inc, July 2000.
6. Leong J: Implementation of random positioning error in computerized radiation treatment planning systems as a result of fractionation. *Phys Med Biol* 32; 327-334, 1987.

7. Lujan A, Larsen EW, Balter JM, Ten Haken RK: A method for incorporating organ motion due to breathing into 3D dose calculations. *Med Phys* 26;715-719, 1999.
8. McCarter SD, Bechham WA: Evaluation of the validity of a convolution method for incorporating tumour movement and set-up variations into the radiotherapy treatment planning system. *Phys Med Biol* 45;923-931, 2000.
9. Davies SC, Hill AL, Holmes RB, Halliwell M Jackson PC: Ultrasound quantitation of respiratory organ motion in the upper abdomen. *Br J Radiol* 67;1096-1102, 1994.
10. Ross CS, Hussey DH, Pennington EC, Stanford W, Doornbos JF: Analysis of movement of intrathoracic neoplasms using ultrafast computerized tomography. *Int J Radiat Oncol Biol Phys* 18;671-677, 1990.
11. Ten Haken RK, Balter JM, Marsh LH, Robertson JM, Lawrence TS: Potential benefits of eliminating planning target volume expansions for patient breathing in the treatment of liver tumors. *Int J Radiat Oncol Biol Phys* 38;613-617, 1997.

12. Kreß J, Minohara S, Endo M, Debus J, Kanai T: Patient position verification using CT images. *Med Phys* 26; 941-948, 1999.
13. Wong JW, Sharpe MB, Jaffray DA: Minimizing intra-fraction organ motion with active breathing control. *Med Phys* 24; 1002, 1997.
14. Wong JW, Sharpe M, Jaffray D, et al. The use of active breathing control (ABC) to minimize breathing motion during radiation therapy. *Int J Radiat Oncol Biol Phys* 44;911-919, 1999.
15. Ritchie CJ, Hsieh J, Gard MF, Godwin JD, Kim Y, Crawford CR: Predictive respiratory gating: a new method to reduce motion artifacts on CT scan. *Radiology* 190;847-852, 1994.
16. Gilhuijs KGA, Drukker K, Touw A, Ven PJ, Herk M: Interactive three dimensional inspection of patient setup in radiation therapy using digital portal images and computed tomography data. *Int J Radiat Oncol Biol Phys* 34;873-885, 1996.

17. Lujan AE, Balter JM, Ten Haken RK: Determination of rotations in three dimensions using two dimensional portal image registration. *Med Phys* 25; 703-708, 1998.
18. Balter JM, Ten Haken RK, Lawrence TS, et. al. :
Uncertainties in CT-based radiation therapy treatment planning associated with patient breathing. *Int J Radiat Oncol Biol Phys* 36;167-174, 1996.
19. Balter JM, Lam KL, Meginn CJ, et.al.: Improvement of CT-based treatment-planning models of abdominal targets using static exhale imaging. *Int J Radiat Oncol Biol Phys* 41; 939-943, 1998.
20. Langen KM, Jones DTL: Organ motion and its management. *Int J Radiat Oncol Biol Phys* 50; 265-278, 2001.
21. ICRU Report 50. International Commisision on Radiation Units and Measurements. Prescribing, recording and reporting photon beam therapy, 1993.
22. ICRU Report 62. International Commission on Radiation Units and Measurements. Prescribing, recording, and reporting photon beam therapy. Supplement to ICRU Report 50, 1999.

23. ICRU Report 29. International Commission on Radiation Units and Measurements. Dose specification for reporting external beam therapy with photons and electron, 1978.
24. Malone S, Crook JM, Kendall WS, et.al.: Respiratory-induced prostate motion: Quantification and characterization. *Int J Radiat Oncol Biol Phys* 48;105-109, 2000.
25. Ekberg L, Holmberg O, Wittgren, et.al.: What margins should be added to the clinical target volume in radiotherapy treatment planning of lung cancer? *Radiother Oncol* 48; 71-77, 1998.
26. Ahmad NR, Huq MS, Corn BW: Respiration-induced motion of the kidneys in whole abdominal radiotherapy: Implications for treatment and late toxicity. *Radiother Oncol* 42; 87-90, 1997.
27. Schwartz LH, Richard J, Buffat L, et.al.: Kidney mobility during respiration. *Radiother Oncol* 32; 84-86, 1994.
28. Korin HW, Ehman RL, Riederer SJ, et.al.:Respiratory kinetics of the upper abdominal organs: A quantitative study. *Magn Reson Med* 23; 172-178, 1992.

29. Harauz G, Bonskill MJ: Comparison of the liver's respiratory motion in the supine and upright positions: Concise communication. J Nucl Med; 733-735, 1979.